

Track ballast in Austria: Part 1.

 In the first part of a comprehensive article, Dipl.-Ing. Christoph Kuttelwascher, Track Expert, ÖBB-Infrastruktur AG, Vienna, Austria and Dipl.-Ing. Michael Zuzic, former Head of Track Division, ÖBB, Vienna, Austria, describe how track ballast can affect the whole rail infrastructure. Literary references (the bracketed numbers) will be detailed in the concluding part of the article.

Regarding cost-effectiveness and longevity of the rail infrastructure, the ÖBB's close cooperation with Austrian and other European universities, as well as civil engineers, has a long tradition. This enables an efficient utilisation of knowledge resources and their combination with practical experience and the prevailing knowledge [1, 2] is complemented by new aspects. Examples given in this article come from references and extracts from investigations that were carried out on the topic of track ballast by Graz University of Technology, Munich University of Technology, Innsbruck University or HTL (technical college) Saalfelden at the request of Austrian Federal Railways (ÖBB).

1. Functions and requirements

In combination with other track components, subsoil, drainage and elastic components, the track ballast is a significant component that has a great influence on the quality and durability of the track. The main functions of track ballast and ballast bed can be summarised as follows:

- Load distribution and triaxial load transfer.
- Resistance against sleeper displacement in all directions.
- Simple restoration of the original track geometry.
- Drainage and maintenance of the load-bearing capacity of the subsoil.
- Retention of rainwater.
- Ventilation.

From these functions, there is a range of requirements to be met by the quality of the ballast itself. In view of the rising stresses due to higher axle loads, and numbers of trains and travelling speeds on the main lines, the aim is to improve the resistance of the track components to the influences and to increase their service life.

An increase of the resistance is achieved usually by improving the material quality and by technological advances in the manufacturing process. With track components such as wooden sleepers or track ballast, the railway has to rely primarily on natural resources and/or geologically developed structures. Track ballast is produced by blasting, breaking-down and screening of solid rock and can generally only be mined where the rock deposits are not covered over by loose sediments such as sand or gravel. The rock deposits that can be found in Austria are listed in section 2.

Solid rock for producing track ballast should fulfil the following conditions:

■ Resistance to weathering and low crack formation

The resistance to weathering must be verified by appropriate expert reports. Numbers, spacing and widths of cracks in the rock have a great influence on the fatigue strength of the rock.

When blasting solid rock by explosives, there will be crack formation in various forms and sizes. If micro fissures are not completely eliminated in the further reconditioning process, this can reduce the strength and resistance of the track ballast. For the highest quality and productivity, the extraction and processing of raw materials must, therefore, be adapted to the respective rock and its place of occurrence.

■ Toughness, hardness and low cleavability

The toughness is the resistance to breaking or expansion of cracks and can be expressed by load-deformation graphs. Crack deflection, crack branching or crack stop ability are influencing factors here [3, 4]. The hardness of a rock is the resistance to mechanical penetration and is the result of mineral hardness, grain binding and hardness of the binding agent between the minerals. The minerals are arranged according to the size of their Ritz hardness using the Mohs hardness test.

For minerals, the cleavability refers to the tendency to break at certain parallel planes in the crystal lattice. The strength of a rock is enhanced by mineral constituents of low or lacking cleavability. Biaxial or triaxial cleavable minerals have a negative effect on the strength [5].

■ No additions of loam, earth or fine particles

After rainfall, the ballast bed must dry out as quickly as possible and this is only guaranteed ideally when there is a high level of air permeability. Larger quantities of fine particles hinder the drainage capacity of the ballast which in the long term can have a negative effect on the load-bearing strength of the subsoil. In addition, fine particles, which in wet condition encase the load-distributing particles like a lubricant, reduce the friction angle and thus lower the shearing strength (see 6.2).

■ Good breaking behaviour (e.g. sharp edges)

The better the breaking behaviour, the greater the interlocking of the ballast stones to each other and to the sleepers which, in turn, produces more favourable load transfer properties and higher resistances to longitudinal and lateral displacements of the track.

2. Geology and rock deposits in Austria

The following types of rock are used in Austria for the production of track ballast.

■ Granite

The greater part of the Bohemian Massif lies to the north of the Danube and accommodates large deposits of granite from which track ballast is produced. Granites are deep-seated magmatic rocks which are formed under high pressure and at high temperatures. They are medium to coarse grained and usually their crystals can be recognised with the naked eye. Their high colour variability is usually determined by the content of feldspar and the colour spectrum ranges from light grey to bluish, and reddish-pink and orange to yellow.

The yellow colours of granite can also occur due to weathering of ferrous minerals (e.g. haematite) to limonite or through weathering of feldspars to clay minerals (kaolinisation). Yellow granites are usually technically poorer than grey granites. Selective mining and regular checks of the weathering indicators are of great significance here. However, discolouration processes can also occur due to ore minerals contained in the rock without the technical properties being altered detrimentally.

Due to their origin, quartz-rich rocks can show a higher susceptibility to impact (quartz crack). However, in carbonate rocks the addition of quartz increases the compressive strength. A high proportion of larger feldspars and mica can have a negative influence on the strength properties due to their complete cleavability [5].

■ Granite porphyry

In Austria, in the transition between the Bohemian Massif and the Molasse zone, there are deposits of granite porphyry which are also suitable for track ballast production. Granite porphyry is a kind of granite but of porphyric structure. In the fine-grained to dense basic mass, there are greater light feldspar crystals or brown biotite plates stored which can be seen with the naked eye. Due to the dense structure, there will often be a metallic sound when struck by a hammer.

■ Granulite

Granulite deposits occur in the old primary rock massifs such as in the Moldanubicum of the Bohemian Massif in the north of Austria (Waldviertel). Granulites are metamorphic stones that have occurred under medium pressure and high temperatures. Their main components are feldspar and quartz, sometimes containing (brown-red) garnets that can be recognised with the naked eye in the often white to dark grey or brownish granulites. Granulite obtained its name from the Latin granulum which means grain. This refers to the usually fine-grained to medium-grained structure (finer than granite) and the uniform texture.

Granulites are suitable for use as track ballast due to their high compressive strength and very high resistance to wear. The granulite deposits in the Dunkelstein Forest are partly veined with serpentinites. However, these are easy to recognise visually and can be eliminated by selective mining.

■ Diabase

Diabase occurs due to metamorphosis (transformation processes under the influence of pressure and temperature) of basalts. Only few diabase deposits in Austria fulfil the stringent suitability criteria for track ballast (e.g. northern Grauwacken zone and Bleiberg Hochtal). The dark green to black-green colour is produced from the first stages of metamorphosis which is the reason why earlier diabase was often called green stone. The proportion of chlorite occurring due to chloritization is decisive for the strength behaviour. In the vicinity of the Bleiberg Hochtal and the Gailtal, diabase with a reddish colour is mined and this colouring is due to minerals such as haematite or magnetite. No detrimental effects on the strength properties have been noted. 

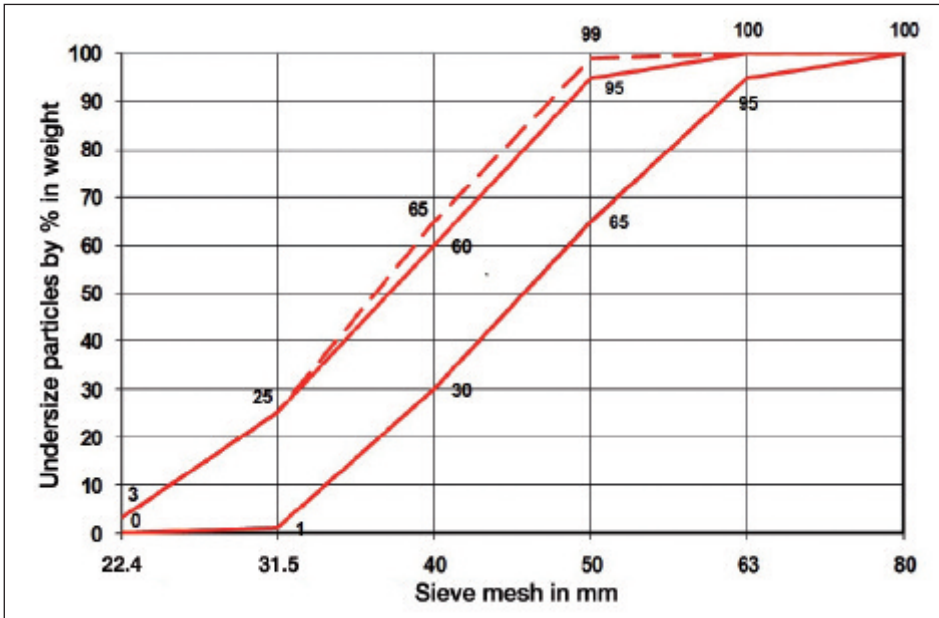

Left: Figure 1: Grading curve of the granulation K1 (31.5/63 mm) (Source: [8])

chemical requirements.

3.1 Geometrical requirements

The chosen grain size distribution must guarantee a suitable load dispersion, load transfer and drainage. Close-grained aggregates have a positive effect on the drainage capability and the elastic properties. However, with increasingly narrower grading, the shearing resistance also drops which is accompanied by the more unfavourable load transfer properties of lower ballast bed stability.

It is here that the particle shape has special significance (due to its equalising function). It can equalise the above mentioned negative aspects of a narrow grading and, therefore, due to the interlocking of the ballast stones, the stability is retained even in the case of close-grained material. However, there will inevitably be peak pressures and consequently the edges of the stones will be broken or chipped off.

Dynamic track stabilisation anticipates stone rearrangement processes and leads to settlements during operation. This raises the number of contact points between the ballast stones and, therefore, reduces the peak pressure.

The granulation K1 (31.5/63) used in Austria, seen in Figure 1, tends towards (in the same way as the granulation for track ballast in Germany) the category Gc RB B (formerly category D) of EN 13450 [9]. For reasons of worker protection, track ballast of granulation K2 (16/31.5) is used wherever the workers have to enter the track regularly in order to carry out work on the vehicles (e.g. parking and marshalling areas).

The proportion of fine particles (< 0.5mm) and finest grain (< 0.063mm) is limited to a maximum of 1.0M% because fine particles in larger quantities can hinder the drainage and also reduce the shearing strength of the ballast bed (see 6.2). Despite correct screening, on open storage depots fine grain fractions from the upper and middle piles may be washed into the lower sections of the pile of material and collect there due to precipitation. In the case of funnel discharge or transport using wheel loaders, it is possible that these areas, in particular, are loaded in a concentrated way. Therefore, in Austria, it is mandatory to perform a screening of the entire ballast material immediately before the loading process. In most cases, the product will be washed at the same time for additional reduction of the fine particles, whereby it is necessary to adapt the flow of water to the material throughput at the vibrating screen. If low-dust ballast is required for special applications (e.g. tunnels), the content of finest grain must not exceed 0.5% in weight and at all times only washed ballast should be used.

To avoid any possible grain fragmentation and demixing during loading, transport and unloading, it is stipulated that when taking specimens on the worksite the undersize portion must be < 22.4 mm or a maximum 5% in weight (maximum 3% in weight in the quarry).

The particle shape is determined in compliance with EN 933-4 [11] and the result is given as the particle shape index. The proportion of stones with a ratio length:width > 3:1 must be between 5 and 30% in weight, carrying out the test on particle groups

Diabase is dense to medium-grained and sometimes the rock develops a porphyric texture due to embedded feldspar.

Basalt

Basalt is a basic volcanic igneous rock occurring as watery lava when it erupts at the earth's surface. It consists primarily of a mixture of iron and magnesium silicates with olivine and pyroxene and calcium-rich feldspar. It is normally dark grey to black, whilst brownish, reddish or grey-green nuances are also possible, and consists for the most part of a fine-grained elementary matter. Due to its very high resistance to pressure and wear, basalt is generally very well suited for track ballast production.

Excepted from this are basalts with a tendency to sunburn. Sunburned basalt is extremely susceptible to weathering, disintegrates easily and is, therefore, not suitable for many technical applications. Sunburn endangered basalt is excluded from delivery to the ÖBB.

In Austria, basalts only occur in the east and south-east (Burgenland, Styria and Carinthia) and here the occurrence came about in three volcanic phases. The most profuse phase is found in the south-east Styrian vulcano region [4].

Dunite, peridotite and bronzite

In the middle Austro-Alpine Grundgebirgsdecke of Styria, there are ultrabasic and ultramafic rocks with various degrees of serpentinisation. Rocks classed as ultrabasic are those with a SiO₂-content of under 45%. Ultramafic is a term given to portions of rocks with over 90% dark minerals of the magmatic rocks [7].

At least 90% volume of dunites consist of olivine, in comparison to the peridotites that consist to 40% to 90% by volume of olivine. As far as the technical utilisation is concerned, the degree of serpentinisation is of decisive significance. Dunites and peridotites have good strength properties as long as the serpentinisation is not too far advanced, whereby high contents of hornblende and augite raise the toughness of the stone.

Serpentinised dunites are mainly dark green to black-blue, whereas serpentinites are brown and brown-grey to black.

Bronzites are very tough, medium

to coarse-grained rocks with greenish brown colouring.

Limestone (dolomite)

Limestone is a sedimentary rock usually of biogenous origin. However, it can also be separated from water by chemical processes and consists mainly of calcium carbonate. In portions, other minerals are also present such as clay minerals, dolomite, quartz and gypsum. If the dolomite portion predominates, then it is generally regarded as dolomite or dolomite stone.

The stone properties and, therefore, also the technical utilisation of limestone can vary greatly. Whereas dolomites and limestones are often classed as medium-hard rocks, there are silicious limestones that are categorised among the hard rocks. The silicification improves the mechanical resistance which is expressed in the fact that the compressive strength is up to twice as high (compared to limestone). Gravel limestone deposits in Switzerland are used there for the production of track ballast.

In Austria, the northern Limestone Alps stretch from Vorarlberg to Lower Austria and consist mainly of limestone or dolomite. For the production of track ballast, these rocks are only partly suitable due to their strength properties.

3. ÖBB conditions of delivery

Track ballast is a natural product and is, therefore, subject to fluctuations in quality. To guarantee the durability of track ballast over a long service life, only hard rocks are used in the Austrian core network. For a long time, rocks were allocated to this group through the definition of cube compressive strength, the content of hard minerals (hardness scale according to Mohs) or the suitability for use as double-broken chippings. The criteria for suitability as track ballast material are given today from the requirements of the ÖBB Supply Conditions [8] on the basis of the European standard EN 13450 [9].

In 2011, the ÖBB drew up a testing system concerning the 'production and supply of track ballast grain size I and II' [10]. This offers the possibility to test the suitability of the quarries even without a firm order. Then the qualified suppliers can be called directly to submit offers. Basically, a distinction is made between geometrical, physical and



Above: Figure 2: Stone sample before and after a Los Angeles test as per [12] (Source: ÖBB).

31.5/50mm and/or 16/31.5mm.

The length of the stone is verified by measuring using appropriate particle shape caliper gauges. On a specimen of more than 40kg delivery granulation (31.5/63mm), the mass portion of grains with a length ≥ 100 mm shall be 6% at the most.

3.2 Physical requirements

■ Impact-attribution strength (Los Angeles coefficient)

The impact-attribution strength is determined according to the Los Angeles testing method in compliance with EN 13450 [9] and EN 1097-2 [12].

To carry out the test, a specimen of 10kg (grain size 31.5/50) following washing and drying is placed in a steel drum (approximately 70cm diameter), together with 12 steel balls (total weight approximately 5.2kg) and rotated 1,000 times around its axis. The speed of rotation is around 30 revolutions per minute. During rotation, the test material is lifted by a ridge on the inner side of the drum and thrown down again. The mechanical stress on the rock is by both impact and attrition through the interactions of steel balls, stones and drum wall. Figure 2 shows a stone specimen before and after carrying out the test, Figure 3 shows a cross-section through the Los Angeles drum.

The Los Angeles coefficient LA_{RB} is

obtained after screening through a 1.6mm sieve according to the formula:

$$LA_{RB} = \frac{10.000 - m}{100}$$

Note: m = material passing through the 1.6mm sieve.

The lower the Los Angeles coefficient, the more resistant the rock is to impact and attrition stress. Generally, only rock with Los Angeles coefficients of a maximum of 22% in weight are utilised as track ballast in Austria. Typical LA_{RB} values of different track ballast rocks in Austria are shown in Figure 8.

■ Impact strength (impact fragmentation value)

The resistance to fragmentation is determined in compliance with EN 13450 and EN 1097-2 [12]. The impact fragmentation coefficient SZ_{RB} is obtained from the mean value of three separate operations. In each case, a mass of around 2.8kg (grain size 31.5/40) is placed in a mortar (17cm inside diameter) after washing and drying and stressed by twenty blows of a drop hammer. The hammer has a mass of 50kg and falls from a height of 42cm. The rock fragmented when this test is carried out is then passed through the 8mm sieve.

The stress on the rock has an impact character and the resulting fractured stone is obtained from the striking energy of the drop hammer on to the specimen. Figure 4 shows

a stone specimen before and after carrying out the test. Figure 5 shows a typical impact testing device.

The impact fragmentation value is calculated according to the formula:

$$SZ_{RB} = \frac{M_1}{M}$$

Note: M = mass of the single measuring specimen before the test; M_1 = material passing through the 8mm sieve.

The lower the impact fragmentation value, the more resistant the rock is to impact stresses. Generally, only rock with impact fragmentation values of maximum 22% in weight are utilised as track ballast in Austria. Typical SZ_{RB} values of different track ballast stones in Austria can be seen in Figure 8.

■ Resistance to wear (Micro-Deval coefficient)

The resistance to wear is determined in compliance with EN 13450 and EN 1097-1 [13]. The Micro-Deval coefficient is produced from the mean value of two separate operations.

Each separate measuring specimen consists of a mass of 10kg of washed and dried fractured stone 31.5/50. This is placed in a drum (20cm diameter) filled with 2.0 l of water and stressed at a speed of 100 revolutions per minute through friction on the inside wall of the drum. After 14,000 revolutions, the specimen is screened

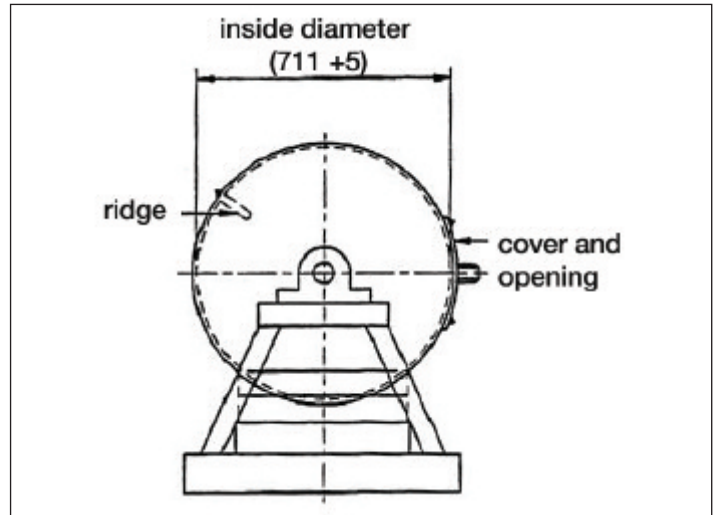

Above: Figure 3: Typical Los Angeles test machine (Source: [12]).



Above: Figure 4: Stone sample before and after an impact fragmentation test as per [12] (Source: ÖBB).

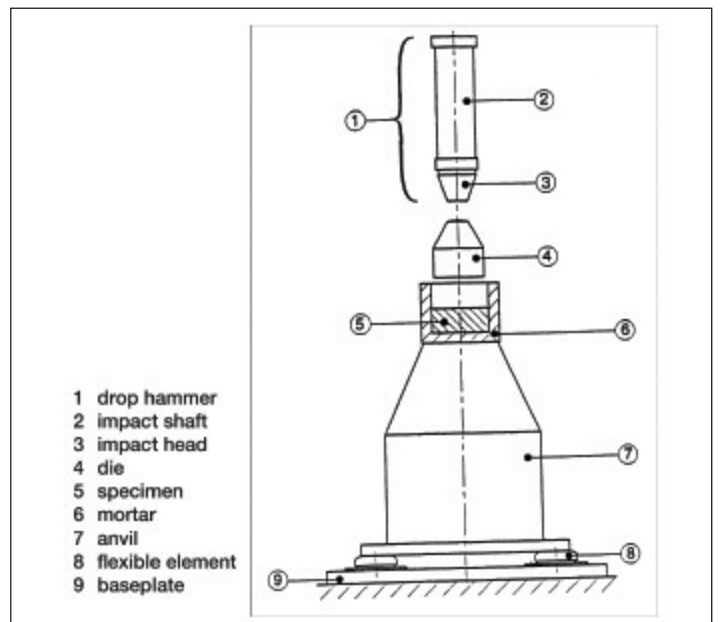

Right: Figure 5: Typical impact testing device (Source: [12]).



Left: Figure 6: Stone sample before and after a Micro-Deval test as per [13] (Source: ÖBB).

Below: Figure 7: Usual test device for Micro-Deval test (Source: [13]).

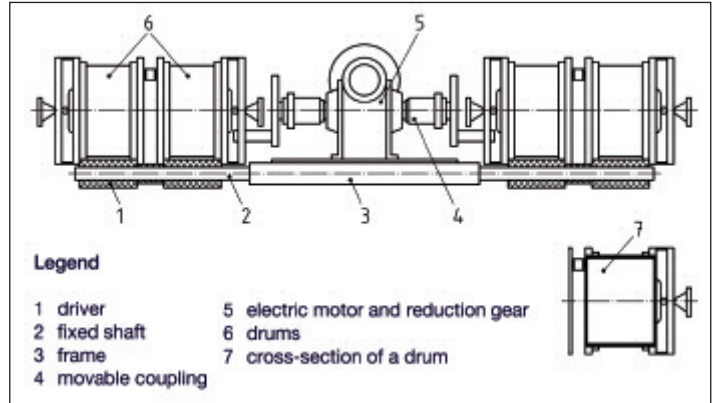

through a 1.6mm sieve. The Micro-Deval coefficient is calculated according to the formula:

$$M_{DeRB} = \frac{10.000 - m}{100}$$

Note: *m* = mass of the material retained on the 1.6mm sieve, in grams.

In the Micro-Deval test, the rock is only stressed by friction. The rock is more resistant to wear the lower the Micro-Deval coefficient and, therefore, the greater the material retained on the 1.6mm sieve. Figure 6 shows a rock specimen before and after testing, Figure 7 shows a normal testing apparatus.

Typical M_{DeRB} values of various track ballast stones in Austria can also be seen in Figure 8.

Gross density

Gross density is determined in accordance with EN 1097-6 [14]. This is the density of the raw stone as a ratio of mass to volume. The mass is determined by weighing the specimen in water-saturated and surface-dried condition and then again in oven-dried condition. The volume contains all pores and cavities specific to the rock. No test value is laid down for the gross density but generally high gross densities are required.

In contrast to the gross density, the bulk density describes the ratio of mass to volume of an unconsolidated, dry stone granulation (loose material). It is equivalent to the lowest compactness including all bulk and bedrock pores. We know from experience that it is roughly equivalent to half the gross density and is, therefore, around 1.3-1.5 t/m³ for track ballast.

The vibration density is that density of a heap of material that is achieved by vibration.

This is equivalent to the maximum achievable dry density in close-grained, coarse aggregates.

Resistance to weathering

The stone used as track ballast must be resistant to weathering. Weathering is a process of stone disintegration due to physical, chemical or biogenous influences and their combinations (e.g. temperature fluctuations, frost, ice, salt, acids).

The evaluation of the resistance to weathering can be made in many different ways - by visual inspection (in the deposit and from broken material), by petrographic expertise and by undertaking a number of laboratory tests. The laboratory tests include the identification of water absorption [14], the resistance to freezing and thawing [15] or the resistance to magnesium sulphate [16]. If there is a suspicion of sunburn in basalt rock, the volume stability must be confirmed in compliance with EN 1367-3 [17].

3.3 Chemical requirements

The chemical requirements assure the ecological acceptance of the rock material and are based on the national regulations concerning recycling and waste dumping. In Austria, these are primarily the Waste Management Act, Federal Waste Management Plan and Landfill Ordinance. At the end of its technical lifespan, the used ballast should then be recycled or be disposed of, if necessary, at low cost.

3.4 Alternative testing methods

Apart from the mandatory testing methods concerning wear and impact strength of track ballast [cp. 18], alternative methods are, in principle, also conceivable. On behalf of

Austrian Federal Railways (ÖBB), studies of five alternatives testing methods were carried out at Graz University of Technology and at HTL Saalfelden (cp. [19]).

The test to determine the compressive strength in the excavated material [20] is a large-scale pressure test using a container similar to an odometer.

Two other testing methods, namely the test to determine grindability of rock by means of a scratch test (Cerchar test) and the grinding and milling test for granulates (Abroy test), were developed to estimate the wearing rate on mining tools, but also enable conclusions to be reached regarding the abrasiveness as a measure of resistance to wear.

Using an adapted triaxial test unit with a constant displacement, the point load test [21] applies a force until the track ballast grain breaks. This also enables conclusions regarding the cleavability and the load deformation behaviour of the rock being tested.

In the course of a modified impact fragmentation test [21], a dynamic load was exerted on the excavated material with ballast granulation K1 (31.5/63mm) using a drop weight under an initial load of 70kg. By definition, the fine grain enrichment is divided into fragmentation (percentage by mass < 22.4mm) and content of fine particles (percentage by mass < 4mm).

All testing methods were carried out in an exemplary way with specimens of rocks suitable for use as track ballast and correlations were investigated with results from the established methods. Some of the results have been published and further developments in the field of standardised quality controls can be expected.

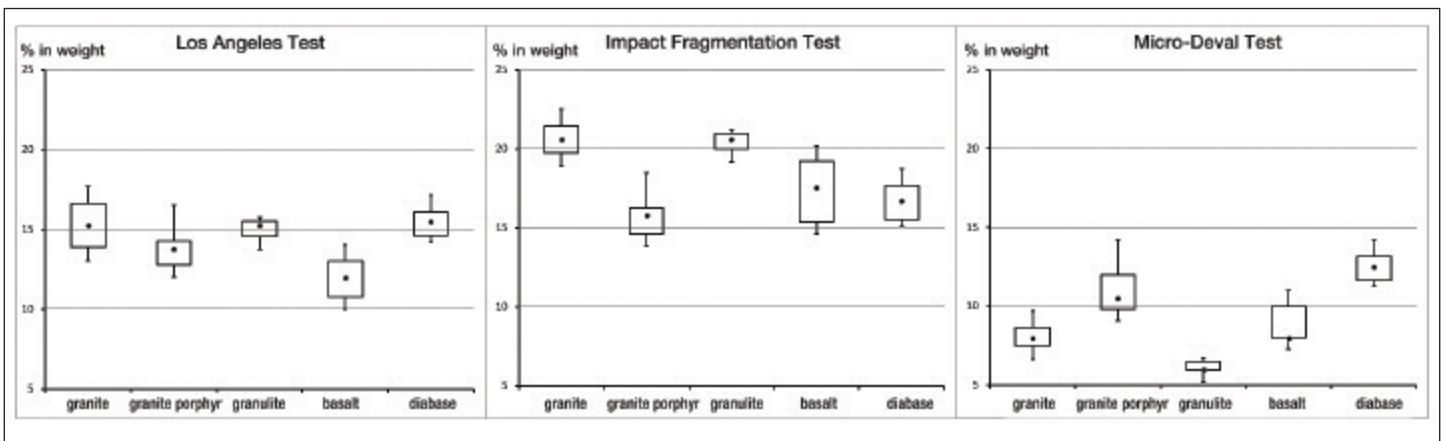

Above: Figure 8: Test results of important track ballast stones in Austria, detailing mean values and a scattering of the mechanical characteristics (2004-2011) as per EN 13450.

Track ballast in Austria: Part 2.

In the second part of their article, Dipl.-Ing. Christoph Kuttelwascher, Track Expert, ÖBB-Infrastruktur AG, Vienna, Austria and Dipl.-Ing. Michael Zuzic, former Head of Track Division, ÖBB, Vienna, Austria, describe how track ballast can affect the whole rail infrastructure. Literary references (the bracketed numbers) will be detailed in the concluding part of the article.

4. Stone mining and selective exploitation

In past years, the ÖBB needed around one million tonnes of track ballast annually (fluctuating above and below this figure) in order to implement all worksites (renewal and maintenance). Depending upon the wagons used (loading quantity), this is equivalent to the figure of around 25,000 to 35,000 wagonloads per year. Unlike other track components, a high proportion of the price of ballast is incurred by transport of the material to the worksite. Besides technical and quality assurance aspects, high demands are placed on daily loading capacities, weekly production capacities and long-term availability in order to guarantee a reliable worksite supply.

The mechanical requirements to be met by track ballast are the highest of all rock products which automatically limits the number of effective suppliers. Deposits of raw material occur homogeneously or are veined with rock zones of lower quality, depending on the geological formation processes. These zones can be excluded from the track ballast production with the help of geological surveys for thorough underground exploration, exact mining planning and selective exploitation - a precondition for consistently high-quality material.

Usually the mining and rock processing for the production of track ballast is carried out in the following main stages: clearing, boring, blasting, transportation, separation, rough-crushing, mineral processing, breaking-down, screening, storing, post-screening and loading.

Normally, the rock is removed from the quarry by large borehole blasting which can cause cracks in different sizes. Optimised borehole spacing and explosive charges minimise the occurrence of micro-cracks. The required K1 granulation is normally produced after the second breaking stage by screening using square-mesh screening on steel or synthetic sieves. Considerations are being made to break up all micro-cracks completely in the reconditioning process because any remaining micro-cracks in the end product have a negative influence on the strength properties.

5. Quality assurance

The ÖBB uses a multi-stage quality assurance system. All suppliers of railway ballast must have CE conformity certification and pursue a certified, regular, internal production control system as per EN 13450 [9].

5.1 Qualification test, inspection tests, intermediate tests

The qualification test (initial test) enables a statement to be made whether the material being mined meets the specified requirements and takes into account all major parameters of EN 13450 [9]. Geological,



Above: Figure 9: Images from the automatic loading control of an ÖBB track ballast supplier showing the video surveillance at various stages of loading - documentation of wagon number, wagon empty, loading process and load weight. (Source: ÖBB).

petrographic and tectonic expert appraisals give information about medium and longer term rock properties in the mining region and enable an estimation of the quality development in the future.

The operational assessment itself is performed by the ÖBB. Expert opinions and test results are referred to in the course of the operational assessment. Ballast specimens are taken on location for a further round of tests and the technical and commercial efficiency of the supplier is assessed.

Inspections (conformity tests) are carried out by ÖBB officials in every supply quarry at least twice a year. They establish whether the quality properties meet the contractual requirements and serve as a conformity certificate of internal monitoring by the manufacturer. The ballast specimens taken at the quarry provide test data that is collected in a central system. Figure 8 (see part 1 of the article) shows examples of time series of typically achieved mechanical characteristics of various types of rock in Austria.

In trade literature there is often mention of the good correlation between LA value and impact fragmentation value. In Austria, such a correlation applies only for a few types of rock (e.g. basalt) whereas other rocks (e.g. granulate) have no correlation (cp. [19]). For this reason, both testing methods are used in the round of tests in Austria.

Intermediate tests (identity tests) serve to monitor the ballast quality at the laying site and can be performed by the ÖBB at any time. When the quantity delivered is over 1,000 tonnes, at least one intermediate test must be carried out on the respective worksite. For worksites with delivery quantities of over 5,000 tonnes at least one intermediate test must be carried out per 1,000 tonnes of material. Normally the grain size distribution is checked, but other stone parameters can be investigated if required.

5.2 Loading

Before ballast is loaded by the supplier, every wagon must be checked so that it is empty in order to avoid incorrect loading or mixing with any possible residue in the ballast wagon. This can be done by visual inspection or by using automatic video surveillance systems. If the latter is chosen, it is possible for the customer to check the loading process in real time.

Figure 9 shows an example of the loading control of an ÖBB track ballast supplier using automatic video surveillance (start-up in 2011). One image is generated at times of predefined stages of loading. Documentation of the wagon number and the wagon in an empty state is made by two images before loading, the documentation of loading by one image during actual loading and another one afterwards.

The automatic recording process is controlled by an interface with the (officially calibrated) belt weigher and documents the current loading quantity. All loading data and photo information are stored in real time on the server to which the customer (scheduling) has direct access.

6. Load transfer and dimensioning of the ballast bed

6.1 Hertz's contact pressure at the rail

One of the most important functions of the ballast bed is to absorb and distribute the static and dynamic wheel loads and to transmit them to the subsoil. The wheel-rail contact patch is only 1-3cm², dependent on their lateral position, the wheel loads applied and the contact geometry (rail wear). Heinrich Hertz's theory enables a calculation of the stresses and their distribution to the contact surfaces of elastic bodies.

For the calculation of the shearing stress occurring at the wheel-rail contact

surface, the following formulae apply according to Hertz's theory with the assumption of a roller contact:

$$2a = 3,04 \cdot \sqrt{\frac{F \cdot r}{2 \cdot b \cdot E}} \quad (\text{mm})$$

Note:

F = effective wheel force (N).

r = wheel radius (mm).

b = half width of rolling surface (mm).

E = modulus of elasticity of the rail steel ($2.1 \cdot 10^5 \text{ N/mm}^2$).

P_{RS} = contact pressure (N/mm²).

Under the simplified assumption (only valid for $r \geq 300 \text{ mm}$)

$$P_{RS} = \frac{F}{2a \cdot 2b} = \frac{F \cdot \sqrt{2 \cdot b \cdot E}}{3,04 \cdot \sqrt{F \cdot r} \cdot 2b} \quad (\text{N/mm}^2)$$

With $E = 2.1 \cdot 10^5 \text{ N/mm}^2$ and $2b = 12 \text{ mm}$ (width of rolling surface) it applies:

$$P_{RS} = 43,5 \cdot \sqrt{\frac{F}{r}} \quad (\text{N/mm}^2)$$

The maximum shearing stress T_{max} , that occurs at a depth of 4mm to 7mm is calculated according to the half-space theory.

$$T_{max} = C \cdot P_{RS}$$

C is a factor that lies between 0.31 and 0.33 with constant surface pressure depending on the type of touch surface.

For the maximum shearing stress T_{perm} it, therefore, applies by approximation:

$$T_{max} = 0.3 \cdot P_{RS} = 13,05 \cdot \sqrt{\frac{F}{r}}$$

6.2 Load dispersion in the ballast bed

With an assumed contact surface of 3cm² and wheelset loads of 225 kN this produces pressures of around 42.000 N/cm² at the rail surface. With other contact geometries, these pressures can rise even higher and must be continuously assimilated and distributed by the individual track components. With a theoretical sleeper supporting surface of around 2,400cm² there will still be pressures, for example on the underside of the sleeper of around 37 N/cm² [23]. However, according to investigations by Munich University of Technology, the effective sleeper supporting surface for uncoated sleepers after consolidation, depending on the number of load alterations, is only around 1-2% of the total sleeper underside area. On the Austrian pre-tensioned concrete sleeper K1 this is equivalent to around 100cm and would indicate very high contact stresses (up to approximately 2,000 N/cm²) [24].

A sufficiently large ballast bed is necessary to distribute the traffic loads over an adequately large area of the substructure and/or subsoil and not exceed its load-bearing capacity. Due to the rail depressions, elastic elements and irregular support conditions, an initial settlement is necessary to distribute the wheel load over several sleepers and to activate the underlying resistance force of the ballast bed even under the adjacent sleepers. The larger the flexural strength of the rail and the lower the stiffness of the trackbed, the more sleepers will be needed for the load transfer. The skeleton track itself is a floating construction in the loose pile of ballast and the traffic loads can be dispersed uniformly into the subsoil only when there are homogeneous support conditions.

The load transfer in the ballast bed is carried out via the contact surfaces of ballast stones to each other, primarily through compressive forces and secondarily through shearing forces. The assumption of a linear

distribution of pressure according to Fröhlich [25] applies only for isotropic and homogeneous materials. In reality, load transfer occurs through randomly formed force paths (Figure 10).

Depending upon load intensity and depth of the ballast bed, individual force paths reach as far as the subgrade even outside the assumed load dispersion angle. To take into account anisotropy and inhomogeneity, Fröhlich used the concentration factor V_k .

The surface pressure on the formation depends on the assumed load dispersion angle of the ballast bed. To ideally utilise the load-bearing capacity, the subsoil (subgrade) and to achieve a uniform course of pressure on the formation, the depth of the ballast bed should theoretically be large enough that the pressure dispersion lines of adjacent sleepers intersect over the formation [1] is produced from:

$$a = \frac{n}{2 \cdot \tan \alpha}$$

Whereby a is the ballast bed depth under the sleeper, n the sleeper spacing and α the load dispersion angle.

Practical experience shows substantial deviations from a homogeneous support due to scattering in the initial consolidation, grain fragmentation as a result of traffic loads or grain size distributions altered by entry of foreign material (e.g. airborne dispersal, spillage). When laying new track, it is especially important to produce a ballast structure in the form of a high-quality, homogeneously compacted ballast bed.

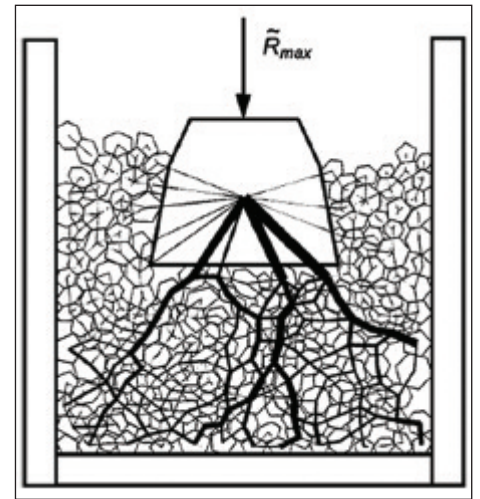

Above: Figure 10: Discontinuous load transfer of the ballast bed (Source: [25]).

When considering the defined target heights, the need for a uniform granular structure as regards depth and grain size distribution should not be neglected (e.g. grain fragmentation due to unacceptably high consolidating energies). In the case of cavities under the sleepers, there are stiffness fluctuations in the ballast bed which result in a concentration of stresses on some localised parts in the granular structure [27].

In the shearing graph, the rise of the shearing strength is determined by the angle of friction ϕ . Large angles of friction favour the

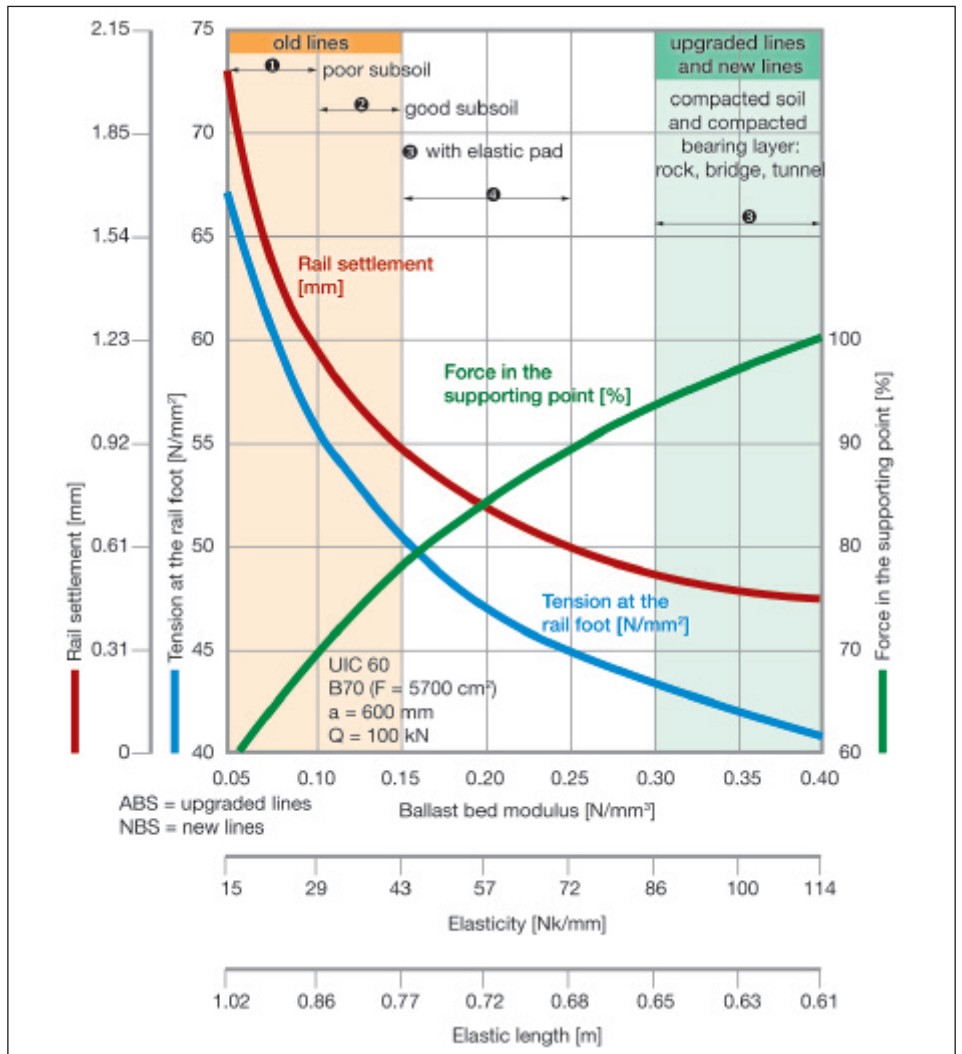

Above: Figure 11: Rail depressions, rail foot tensions and supporting point force with various ballast bed moduli, spring characteristics and elastic length and a wheelset load of 100 kN (Source [23]).

ballast bed stability and ensure good load distribution, activation of large quantities of ballast and a reduction of the strain on the subsoil. The friction angle is determined mainly by the grain size distribution (irregularity, density) as well as shape, roughness, sharp edges and edge stability of the grains. Many of these parameters are not influenced by stone processing and are basically defined by rock properties and mineralogy. To measure additional geometrical influencing parameters, such as sphericity (shaped like a ball) and degree of roundness, tests were carried out by the ÖBB in 2012 on all types of rock suitable for track ballast using the Petroscope at Graz University of Technology. For this, a quantity of separate stones is scanned by a laser beam which enables the degree of roundness and the shape index to be identified.

When wet, fine particles in large quantities act like a lubricant, reduce the friction angle and, therefore, lower the shearing strength. This results in unfavourable load transfer properties and high stress peaks. They also bind water through capillarity action, delay the drying out of the subsoil and can, therefore, in the long-term reduce the load-bearing strength which leads to settlements.

In various literature the load dispersion angle of new track ballast in the ballast bed is stated at times with up to 45°. Studies at Innsbruck University commissioned by the ÖBB produced in laboratory tests far lower values of around 20° (at 90% load quantiles) for new ballast. To evaluate the conditions on the open line, tests on load dispersion were carried out on various kinds of rock and stone shapes during innovation measuring runs in 2012 on real track on the new western main line Vienna-St. Pölten in the vicinity of Tullnerfeld.

6.3. Track calculation and stress on the ballast

The stress on the ballast is normally expressed in terms of the ballast pressure. This results from the load on a sleeper in relation to the effective supporting surface of the sleeper in the ballast. The greatest loads in the ballast bed, which destroy the ballast stones, are primarily quasistatic and dynamic vertical loads. Discontinuities in the track (e.g. switch points, joint gaps) or on the vehicle (e.g. flat spots) produce localised, dynamic force peaks. Abrupt differences of stiffness in the subsoil (e.g. bridge transitions) and non-uniform layer densities of the ballast bed react in turn on the load transfer (foundation soil-framework interaction).

Zimmermann's method on the basis of

Type of subsoil	Ballast bed coefficient C [N/cm ²]
very poor subsoil (organic soils, homogeneous sand)	0.02
poor subsoil (cohesive soil, not durable track geometry)	0.05
good subsoil (gravel)	0.10
very good subsoil	0.15
concrete floor (bridges, tunnels)	≥ 0.30

Above: Figure 12: Ballast bed modulus depending upon type of subsoil (Source: [22]).

considerations by Winkler [28] is applied to evaluate the stress on the track components. Although not accepted unconditionally in detail, Zimmermann's method [29] produces reliable results for the purposes of measuring and is applied at ÖBB in the form of Regulation B 50-Part 3 [22]. Here the rails are regarded as bearers on an elastic foundation with the ballast bed modulus C. The ballast bed modulus C describes the relationship between the surface pressure of the supporting point and the depression and, therefore, also contains the elasticity of the ballast bed and the subsoil. The formulae is:

$$C = \frac{P}{y}$$

C = ballast bed modulus (N/mm³).

P = surface pressure between sleeper and ballast (N/mm²).

y = depression of the rail (mm).

Elastic elements such as rail pads, elastic coating on the underside of sleepers or sub-ballast mats can be taken into account by superposition.

The rail deformations are dependent upon wheel load, rail stiffness, stiffness of the supports and sleeper spacing. As illustrated in Figure 11, there are greater deformations on soft subsoil and, therefore, greater stress on the rails. On the other hand, hard subsoil leads to high supporting point forces and the associated higher stresses on the ballast. The use of elastic coatings on the underside of sleepers and sub-ballast mats, for example, can help to reduce these stresses [31].

In the ÖBB Regulation B 50-Part 3 [22], the ballast bed moduli illustrated in Figure 12 are applied. The ballast bed modulus can be determined by depression measurements, rail foot tensions or knowledge of the bending wave at a given vertical load using the

following formulae:

■ From the rail foot tension:

$$C = \frac{4 \cdot E \cdot I \cdot a}{A} \cdot \left(\frac{F}{4 \cdot \sigma_f \cdot W_u} \right) \quad (\text{N/mm}^3)$$

■ From the depression of the rail:

$$C = \frac{F \cdot a}{4 \cdot y \cdot A} \cdot \sqrt[3]{\frac{F}{E \cdot I \cdot y}} \quad (\text{N/mm}^3)$$

■ From the length of the bending wave between the points a and b (Figure 13):

$$L = \sqrt[4]{\frac{4 \cdot E \cdot I \cdot a}{A \cdot C}} \quad (\text{mm}) \quad \& \quad C = 2000 \cdot \frac{E \cdot I \cdot a}{A \cdot D^4} \quad (\text{N/mm}^3)$$

Calculated ballast pressure under the sleeper

The basis of the calculation according to Zimmermann is the conversion depicted in Figure 14 of the cross-sleeper support surface in equal surface longitudinal sleepers.

a = sleeper spacing.

b = width of the assumed longitudinal beam.

ü = sleeper overhang.

2ü = sleeper length minus wheel contact point distance (1,500mm on standard gauge, 805mm on narrow gauge).

$$A_1 = A_2 = A$$

$$A_1 = 2 \cdot \ddot{u} \cdot b_1$$

$$A_2 = b \cdot a$$

$$b = \frac{2 \cdot \ddot{u} \cdot b_1}{a} = \frac{A_1}{a}$$

b₁: Slanting edges and narrowings in the middle of the sleeper should be taken into account for concrete sleepers.

The ballast pressure p under the sleeper results from p=C•y, the depression y according to the formula:

$$y = \frac{F \cdot a}{2 \cdot A \cdot C \cdot L} \cdot \eta$$

L describes the fictive sleeper length and produces

$$L = \sqrt[4]{\frac{4 \cdot E \cdot I \cdot a}{A \cdot C}}$$

A = half supporting sleeper surface (mm²).

a = sleeper spacing (mm).

C = ballast bed modulus (N/mm³).

p = surface pressure between sleeper and ballast (N/mm²).

y = depression of the rail (mm).

E = modulus of elasticity of the rail steel (2.1•10⁵ N/mm²).

F = effective wheel force (N) in compliance with EN 15528.

L = fictive sleeper length as a basic value of the longitudinal sleeper track.

I_x = moment of inertia of the rail (mm⁴).

η = Zimmermann's influencing factor.

φ = speed factor.

n = speed reversals.

The effective wheel force F is produced from the static wheel force and an addition (10 to 20%) for the wheel force displacement when travelling through curves.

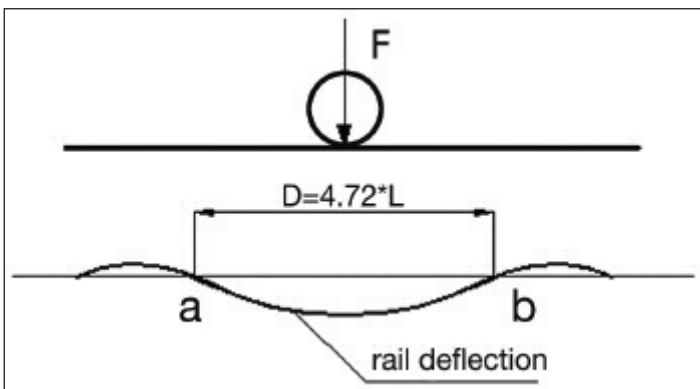

Above: Figure 13: Bending line between the points a and b (Source: [22]).

Right: Figure 14: Conversion of the cross-sleeper track in a theoretical long-sleeper track (Source: [22]).

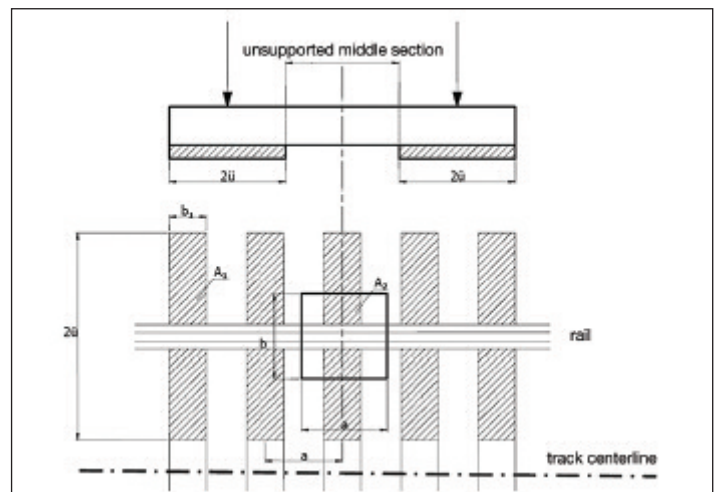

Track ballast in Austria: Part 3.

In the final part of their article, Dipl.-Ing. Christoph Kuttelwascher, Track Expert, ÖBB-Infrastruktur AG, Vienna, Austria, and Dipl.-Ing. Michael Zuzic, former Head of Track Division, ÖBB, Vienna, Austria, describe how track ballast can affect the whole rail infrastructure. Literary references (the bracketed numbers) are detailed at the end of the article.

Zimmermann's influencing factor η takes into account the influence of several vehicle axles and is contained in the ÖBB regulation B50-Part 3 in spreadsheet form. It is set at 1.0 for a single load in the middle of the sleeper.

The scatterings of the effects (quasi-static and dynamic stresses) and resistances (ballast, cavities, subsoil) are taken into account by additions for speed and state of repair and summarised in the factor \bar{s} ($\bar{s} = \bar{n} \cdot \phi$). The speed factor ϕ is obtained from the maximum line speed and is between 1 and 1.5. The factor n lies between 0.15 and 0.25 and is obtained from the line category and track classification.

6.4. Resistances to lateral displacement

The resistance to lateral displacement is a decisive parameter for measuring the stability of the track to buckling and depends on a large number of factors (sleeper geometry, contact surfaces, grain size distribution, grain shapes, angularity, amount of ballast around the sleeper edges). It is that reaction force that counteracts a displacement of the track perpendicular to the centre line of the track (normally after a 2mm displacement path).

The resistance to lateral displacement is composed of the following resistances:

- Sleeper underside friction. Resistances at the sleeper underside dependent on load, contact surface and interlocking and/or coefficient of friction. According to [24] a distinction is made between primary and secondary sleeper underside resistance.
- Shoulder resistance. Active soil pressure



Above: Figure 15: Test rig during the fatigue level test. (Source: ÖBB).

as per soil pressure theory dependent on coefficient of friction, height of layer and material characteristics.

■ Sleeper-end resistance. Passive soil pressure as per soil pressure theory becomes effective only from a certain movement.

After ballast bed cleaning or tamping, the resistances to lateral displacement are reduced by between 40 and 50%. The dynamic track stabilisation increases the resistance to lateral displacement by between 30 and 40% [23]. The percentages of the part resistances given in trade literature fluctuate depending upon the measuring method used. However, all in all, approximately half of the total resistance to lateral displacement is determined by sleeper underside friction and on elastic-coated sleepers up to around 60%.

To establish the influence of different types of ballast (granite and dunite), elastic coatings and safety caps on the resistance to

lateral displacement, tests were commissioned by ÖBB in 2010 and carried out by Munich University of Technology using the single-sleeper method and have been published in [24].

To perform the measurements a skeleton track with two uncoated K1 pre-tensioned concrete sleepers was set up in the test rig. The depth of the ballast bed was 45cm which is equivalent to a ballast depth of 23cm below the lower edge of the sleeper. Sub-ballast mats of varying stiffness ($C_{stat} = 0.045 \text{ N/mm}^3$ and 0.28 N/mm^3) were used to simulate the subsoil. Ballast bed consolidation was performed using a vibrating plate and a manual packing device. The test set-up can be seen in Figure 15.

Depression, stiffness, ballast bed modulus

The depressions under static and dynamic load were measured using inductive transducers. After a simulation of three million load alternations with an upper load of 225 kN, the static and dynamic ballast bed moduli, the settlement behaviour and the resistance to lateral displacement of the individual sleepers were established.

When the consolidation condition is reached after around 250,000 load alternations, the oscillation amplitude (decline of elastic deformations) drops, whereas the plastic deformations continue to increase.

With the same grading curve the dunite showed during the fatigue level test, compared to granite, a lower static and dynamic stiffness combined with greater plastic deformations. After three million load alternations the plastic deformation of the granite ballast on stiff subsoil ($C_{stat} = 0.28 \text{ N/mm}^3$) was around 6mm, whereas that of the dunite was around 9mm. After a load of 3 million load alternations the static ballast bed modulus was on average around 0.155 N/mm^3 and the dynamic ballast bed modulus was around 0.195 N/mm^3 .

For the test the sleeper-end ballast was 0.50m horizontal and the adjoining

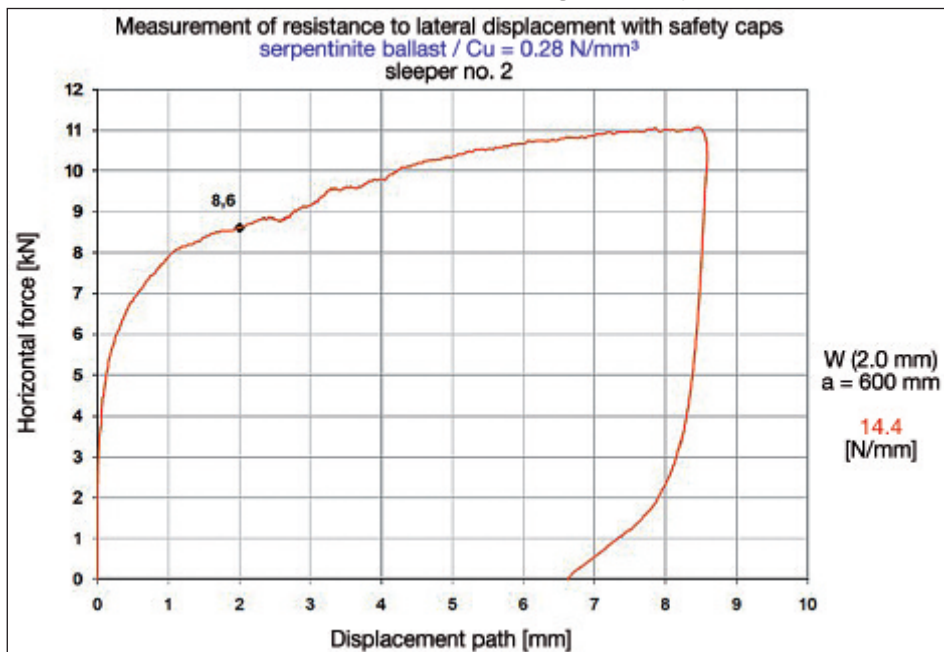

Above: Figure 16: Resistance to lateral displacement graph of a single sleeper measurement with safety caps. (Source: ÖBB).

Right: Figure 17: Calculated resistances to lateral displacement of individual sleepers after the fatigue level test with three million load alternations. (Source: ÖBB).

embankment slope was 1:1.5. After the entire loading cycle the rails were uncoupled from the sleepers to measure the resistances to lateral displacement. Then, the individual sleepers were displaced crosswise to the centre line of the track, without a vertical load. The horizontal load was commenced in the neutral axis of the sleeper, the force occurring at the 2mm deformation path (transition static friction - sliding friction) was taken as a ruling resistance force. The calculation was made through the relation to the sleeper spacing of 600mm in the unit N/mm.

Figure 16 shows a typical force-deformation curve of a resistance to lateral displacement measurement with safety caps.

Figure 17 shows with dunite ballast on soft subsoil a lateral resistance increased by 27% (compared to hard subsoil), which is due to a higher density through the larger oscillation amplitude and greater plastic deformation due to the rearrangement processes. On hard subsoil, the resistance to lateral displacement to granite ballast is slightly reduced due to the lower stability of the edges.

Due to temperature expansions, high forces act to the outer side of the curve, especially in very tight curves, which without additional measures would produce unacceptably high deformations. Here safety caps are applied as a means to increase the resistance to lateral displacement. The resistances to lateral displacement were also measured with safety caps installed in order to check their effectiveness. Here the increase of the resistance to lateral displacement was on average around 30% (Figures 16 and 17). With ballast bed depths over 45cm a further increase can be expected due to the additionally activated pressure cone downwards.

7. Reduction of the mechanical track ballast loads

Uniform consolidation and homogeneity of the ballast bed are important requirements to reduce the loads on the ballast structure. Immediately after mechanised ballast bed cleaning and tamping, the ballast is only compacted in the influencing zone of the tamping tines. A homogeneous consolidation in the entire cross-section is aimed at through the application of dynamic track stabilisation. Irregular settlements due to traffic loads are reduced and anticipated in a uniform way, increasing the resistance to longitudinal and lateral displacements and reducing cavities under the sleepers. The dynamic track stabilizer exerts a vertical load on the track and places it in horizontal oscillations of 30-37 Hz. Due to the low ballast pressure of approximately 8 N/cm², this is also referred to as 'force-free spatial consolidation' [31].

Another course of action to extend the service life of the ballast bed is the specific application of elastic elements such as elastic coating on the undersides of sleepers and sub-ballast mats. The resulting lower mechanical

Right: Figure 18: Visible ballast stone contact surfaces of an elastic-coated frame sleeper in the St. Pölten area. (Source: ÖBB).

	Resistance to lateral displacement [N/mm]			
	Upper load = 225 kN, lower load = 8 kN, frequency = 3 Hz			
	dunite soft subsoil C _v = 0,045 N/mm ³	granite hard subsoil C _v = 0,028 N/mm ³	dunite hard subsoil C _v = 0,028 N/mm ³	dunite with safety caps hard subsoil C _v = 0,028 N/mm ³
Measurement 1	13.4	11.8	10.7	14.7
Measurement 2	13.6	11.8	10.6	15.1
Mean value	13.5	11.8	10.7	14.8

stresses on the ballast stones result from the more uniform support conditions on the one hand and from a dampening of the dynamic pulses from the traffic loads on the other. Due to the use of elastic undercoating, the contact surfaces between sleeper and ballast can be multiplied [24].

An increase of the contact surfaces is also obtained through modified sleeper dimensioning, for example frame sleepers (Figure 18) or HD sleepers.

8. Outlook

The quality of the track ballast used in the line network of Austrian Federal Railways is regulated by the 'Production and Supply of Track Ballast' and by the technical conditions of delivery for track ballast (BH 700). The European standard EN 13450 serves as a basis for the requirements.

All suppliers of railway ballast must have CE conformity certification and pursue a certified, regular, internal production control system. Typically, the quality is guaranteed by initial testing, conformity testing and identity testing.

In the EN 13450, the Los Angeles testing method has been laid down as a European reference method to determine the resistance of track ballast to fragmentation. The foundation was tests carried out by the European Rail Research Institute (ERRI) in 1991 and 1992. Practical experience shows that a single referencing on the Los Angeles coefficient (LA value) does not completely reflect the experience of the Austrian rail network. Therefore, Austrian Federal Railways also uses the impact fragmentation coefficient and the Micro-Deval coefficient as additional quality criteria. In addition, over past years, alternative testing methods have been investigated, further

developed and in some cases published [19]. Some of these testing methods are suitable for routine application and may lead to further development in this sector.

In order to correctly evaluate the behaviour of the Austrian track ballast in the rail network of Austrian Federal Railways, and to draw conclusions about quality figures, a great number of investigations were carried out in the ÖBB rail network in the years 2010 to 2012 in the course of a project on the systematic observation of the subject of track ballast. Taking into account the framework conditions such as track components, drainage, subsoil stiffness, etc, ballast samples were taken and material tests were performed by accredited test institutes and universities.

It is evident that only a systematic view (in technical, organisational and commercial terms) will be effective. For example, modifications of technical requirements automatically have effects on supplier structure, transport costs and worksite logistics. On a technical basis all components of the track must be compatible. As a part of this system, the track ballast used plays an important role. When there is insufficient drainage, poor subsoil or dynamic stresses due to discontinuities in the track structure, even the highest quality track ballast cannot compensate for the deficiencies in the overall system.

An important commercial difference of track ballast to other track components is that the transport costs make up a high proportion of the overall costs for supplying ballast to the worksite. The requirement of maximum track ballast quality at a low price, with the best possible assurance of supply and minimum transport distances, shows the necessity of regarding the subject of track ballast systematically.



Literary references

- [1] Klotzinger, E. (2008): Track ballast. Part 1: Requirements and stress. In: ETR, 01-02/2008.
- [2] Klotzinger, E. (2008): Track ballast. Part 2: How quality develops over time and thresholds for action In: ETR, 03/2008.
- [3] Issler, L./Ruoß, H./Häfele, P. (2003): Science of material strength - Fundamentals.
- [4] Dietrich, H. (1994): Mechanical Testing of Materials: Foundations, Testing Methods, Applications.
- [5] Anthes, G. (2006): Study Fundamental inquiry into deposits of granite stone in Austria.
- [6] <http://www.volcanodiscovery.com/de/vulkane/lexikon/basalt.html>
- [7] <http://www.wikipedia.org>
- [8] Technical conditions of delivery for track ballast BH 700; ÖBB Infrastruktur AG, 1. Aug. 2007.
- [9] ÖNORM EN 13450 Aggregates for track ballast; Austrian Standards Institute in the applicable version.
- [10] ÖBB Infrastruktur AG (March 2011): Testing system as per Article 53 RL 2004/17/EG in the applicable version concerning the 'production and supply of track ballast of particle size I and II'.
- [11] ÖNORM EN 933-4 Tests for geometrical properties of aggregates, Part 4: Determination of particle shape - Shape index. Austrian Standards Institute in the applicable version.
- [12] ÖNORM EN 1097-2 Tests for mechanical and physical properties of aggregates. Part 2: Methods for determination of resistance to fragmentation. Austrian Standards Institute in the applicable version.
- [13] ÖNORM EN 1097-1 Tests for mechanical and physical properties of aggregates. Part 1: Methods for determination of resistance to wear (Micro-Deval). Austrian Standards Institute in the applicable version.
- [14] ÖNORM EN 1097-6 Tests for mechanical and physical properties of aggregates. Part 6: Determination of particle density and water absorption. Austrian Standards Institute in the applicable version.
- [15] ÖNORM EN 1367-1 Tests for thermal and weathering properties of aggregates. Part 1: Determination of resistance to freezing and thawing. Austrian Standards Institute in the applicable version.
- [16] ÖNORM EN 1367-2 Tests for thermal and weathering properties of aggregates. Part 2: Magnesium sulphate test. Austrian Standards Institute in the applicable version.
- [17] Austrian standard EN 1367-3 Tests for thermal and weathering properties of aggregates. Part 3: Boiling test for sunburned basalt. Austrian Standards Institute in the applicable version.
- [18] ORE (1991): Uniform assessment criteria of ballast quality and evaluation methods of ballast condition in the track. Question D 128. Report No. 2.
- [19] Bach, H./Kuttelwascher, C./Latal, C. (2012): Alternative testing methods for quality assurance of track ballast. In: ZEVrail, 3/2012.
- [20] Swiss Association of Road and Traffic Specialists (February 2008): SN 670 830b Test procedure for mechanical and physical properties of aggregates - method for determining the compressive strength of track ballast.
- [21] Breyman, H. (2011): Mechanical criteria for the track ballast - point load test, fragmentation. Report to the ÖBB (unpublished).
- [22] B 50-Teil 3 (März 2012): Permanent way calculation. ÖBB Infrastruktur AG.
- [23] Lichtberger, B. (2003): Track Compendium.
- [24] Iliiev, D. (2012): The horizontal track geometry stability of the ballasted track with conventional and elastic coated sleepers. In: Munich University of Technology, Road Construction Department and Testing Office, Publications: Brochure 86.
- [25] Fröhlich, O. K. (1934): Pressure distribution in the foundation soil.
- [26] Kruse, H. (2002): Model-assisted investigations of track dynamics and the behaviour of railway ballast. Dissertation submitted to Hanover University.
- [27] Holtzendorff, K. (2003): Investigation into the settlement behaviour of railway ballast and the development of cavities on ballasted tracks; Dissertation submitted to Berlin University of Technology.
- [28] Winkler, E. (1867): The science of elasticity and stability.
- [29] Zimmermann, H. (1941): Calculation of railway permanent way.
- [30] Auer, F./Schilder, R. (2009): Technical and commercial aspects on the topic of soled sleepers - Part 1: long-term experience in the ÖBB network. In: ZEVrail. April 2009.
- [31] Lichtberger, B. (2007): The Lateral Resistance of the Track. In: EIK 2007. 